

## Air-handling units



## CONTENTS

Main features .....	2
Construction .....	4
Outputs and functions .....	6
Output of heaters .....	7
Output of coolers.....	7
Heat exchangers .....	7
Choice of equipment and composition of units .....	8
According to output and functions .....	8
The composition of the unit sections is done according to the Positional numbers.....	8
According to location.....	8
Assembly and connection.....	9
Assembly of units.....	9
Connecting of the ductwork .....	9
Unique side variability for connections and accesses.....	9
Suspension.....	9
Media Connection .....	9
Construction of units .....	10
Module .....	10
Section .....	10
Co-section .....	10
Joint arrangement .....	11
Examples of compositions .....	12
Fans .....	16
Noise-attenuation.....	18
Filters .....	19
Mixing .....	22
Heat Recovery .....	24
Co-sections.....	25
FPSO double section – filter (frame) + el. heating.....	25
FPSY double section – water cooler + eliminator.....	26
FPSY double section – direct cooler + eliminator.....	27
FPSC co-section – filter (frame) + water heating + fan .....	28
FPSE co-section – filter (frame) + el. heating + fan .....	29
FPSV co-section – filter (frame) + water heating + cooler + eliminator .....	29
FPSW co-section – filter (frame) + electric heating + cooler + eliminator .....	30
Easy access to an offer.....	31

# MAIN FEATURES



**SMALL, BUT FULL-BLOODED**

## AIR-HADLING UNITS

AeroMaster FP units are intended for air handling and air conditioning in smaller rooms, especially with higher demands on the acoustic and thermodynamic parametrs.



### EASY SELECTION

- Comprehensive selection in AeroCAD software.
- Read-out of standard versions on the internet.



### ALL FUNCTIONS

- Comprehensive units, including heat and recovery.



### QUICK DELIVERY

- EXW despatch in 5 days, immediate delivery of basic versions.

# MAIN FEATURES



## EXCELLENT NOISE PARAMETERS

- Insulation of top and bottom panel: 25 mm
- Insulation of side panel: 40 mm



## SMART DESIGN

- Through its design, the unit is predetermined for use in even demanding places.
- The version with outside plate with colored coating RAL 9002, can be delivered as custom made.



## ALTERNATIVE SIDE CONNECTION

- Most of the built-in parts can easily be connected from both sides.



## LOW HEIGHT

- Total height is only 360 mm.

# CONSTRUCTION

Thanks to their original frameless structure AeroMaster FP units are characterized by top parameters according to the European standard EN1886.

■ CASING MECHANICAL STRENGTH	D2
■ CASING AIR LEAKAGE	L3
■ FILTER BYPASS LEAKAGE	< 1% (F8)
■ THERMAL INSULATION	T3
■ THERMAL BRIDGING	TB2
■ ACOUSTIC INSULATION OF CASING	Dpr, w= 28 dB
■ WORKING TEMPERATURE	-40 ~ +40°C



**MODERN FRAMELESS CONSTRUCTION**

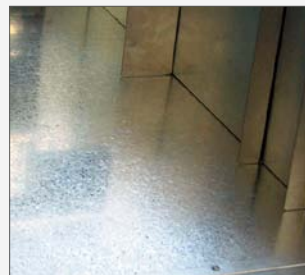

**TOTALLY SMOOTH SURFACE**



**FANS WITH OVERHUNG IMPELLER**



# CONSTRUCTION



**ELECTRIC HEATERS WITH SWITCHED ELECTRONICS**



**HEAT EXCHANGERS WITH INTEGRATED BYPASS**



**EASILY REMOVABLE FILTERS**



**SIDE HANGINGS FOR EASY INSTALLATION**

# OUTPUTS AND FUNCTIONS

## AEROMASTER FP UNITS OUTPUTS

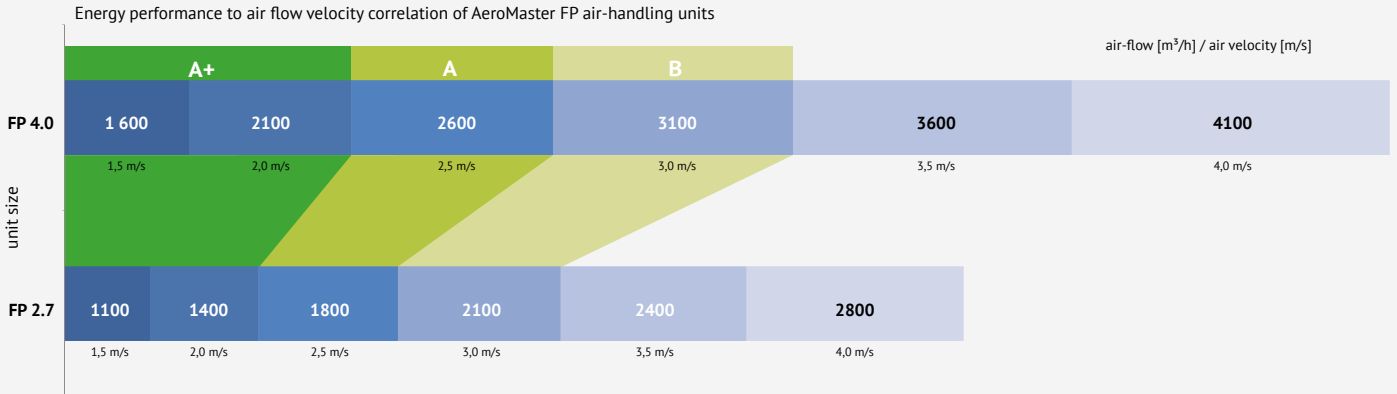

Pressure difference of fans:

■ up to 1000 Pa

Inlet air temperature:

■ -40°C ~ +40°C

FP 4.0 series dimensions:

■ Full cross-section 995 x 360

■ Inside cross-section 915 x 310

FP 2.7 series dimensions:

■ Full cross-section 690 x 360

■ Inside cross-section 610 x 310

## FUNCTIONS

AEROMASTER FP UNITS BASIC FUNCTIONS				
Function	Version 1	Version 2	Version 3	
Fans	with backward curved blades			
Heating	electric	water		
Cooling	water	direct		
Heat recovery	plate exchanger			
Humidification				
Mixing				
Filtration	EU3 (metal filtration cell)	EU3-EU9 (bag filter)	EU4 (frame filter)	
Noise attenuation	absorption splitter noise attenuators			



# OUTPUTS AND FUNCTIONS

## OUTPUT OF HEATERS

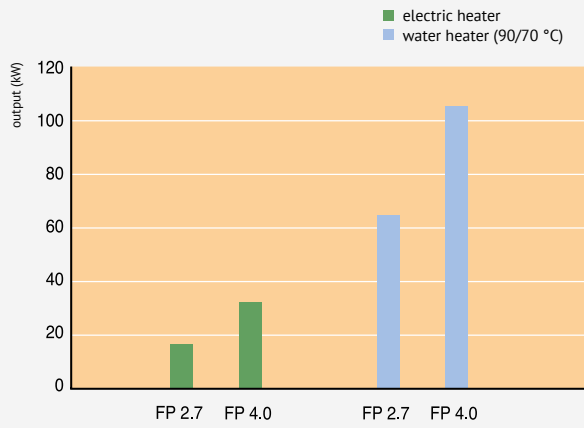

## OUTPUT OF COOLERS

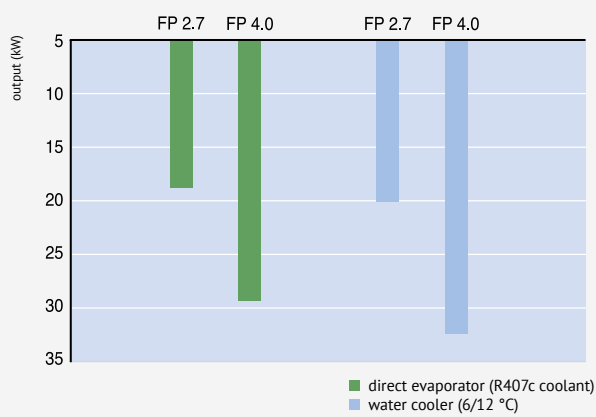

## HEAT EXCHANGERS

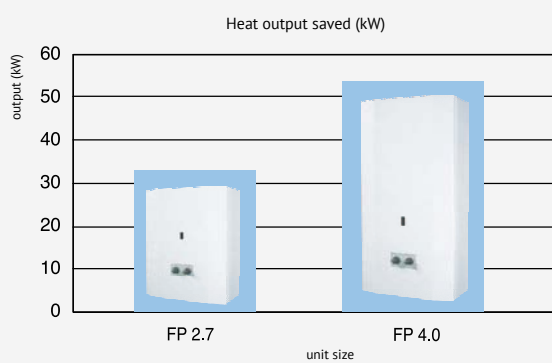

# CHOICE OF EQUIPMENT AND COMPOSITION OF UNITS

## ACCORDING TO OUTPUT AND FUNCTIONS

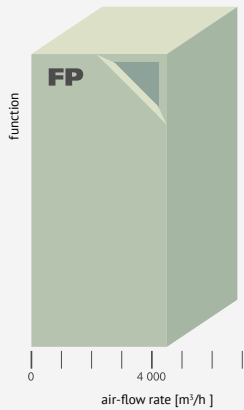

- transport of air
- heating (electric, water)
- cooling (direct, water)
- filtration
- elimination of drops
- heat recovery
- mixing

## ACCORDING TO LOCATION

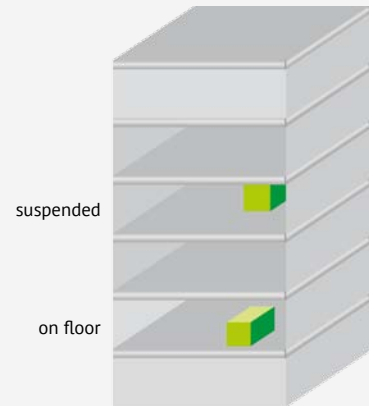

## THE COMPOSITION OF THE UNIT SECTIONS IS DONE ACCORDING TO THE POSITIONAL NUMBERS.

These numbers are listed in the printed composition, which is a delivery component, and on the manufacturing plate of each section.

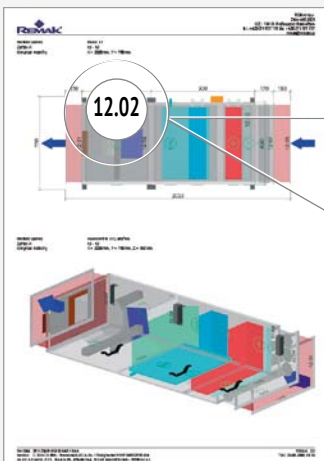

REMAK		CE	PC
REMAK s. r. o. Zvolenská 1014, CC-PK 01, Hubertov, 534 01 Znojmo, Czech Republic			
Číslo zakázky	052938	Grado P	12.02
Název zakázky	03.05	03.05	
Poslední číslo			
Učtový výrobek	01.06.2015		
<b>Sekce ventilátora</b>		<b>FP5A 2</b>	
Výrobci kód	FP5A027Z		
Celkem	230270100		
Hmotnost	46 kg		
Průměr	1100 mm		
Nominální tlak vzduchu	800 Pa		
Tlakový zisk pro výpočet	FPVAK 110-46-80-0,56-2		
<b>Ventilátor</b>			
Výrobci kód	FPVAK027AU0700-		
Státní tlak	650 Pa		
Čerkačský tlak	681 Pa		
Výkon motoru	0,56 kW		
Průtok	2,36 m³/s		
Účinnost	43 %		
Hmotná síla	160 mm		
Zahradní spánek	Dogfishu		
Průtok	2002 l/min		
Čistota vzduchu	1113 m³/h		
Průtok vzduchu max.	650 Pa		
Čerkačský tlak max.	1 x 230 / 150 V / Hz		
Nominalní napětí	0,30 A		
Výkon motoru max.	2		
Rámcový proud max.	2		
Průtok (D0)	2		
Termokontakty	2		
Krytí	IP 55		
Třída ochrany	F		
Typ regulace	troubové		
Regulátor výkonu	XPR116.05 (1x230V)		
Výrobce kód	0110021100		

# ASSEMBLY AND CONNECTION

## ASSEMBLY OF UNITS

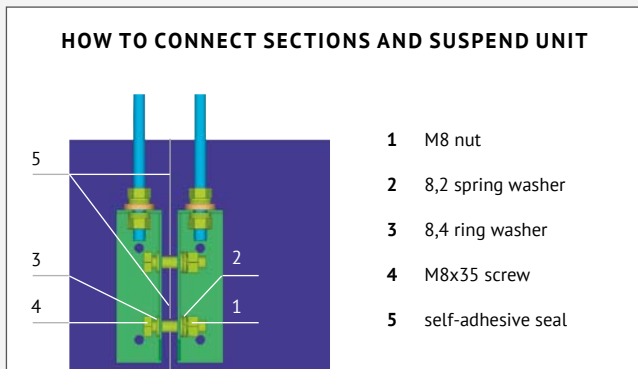

Bolted connections ensure a firm connecting of the unit's sections. The connecting of a unit that is composed of three sections can be done in 30 minutes.

## SUSPENSION

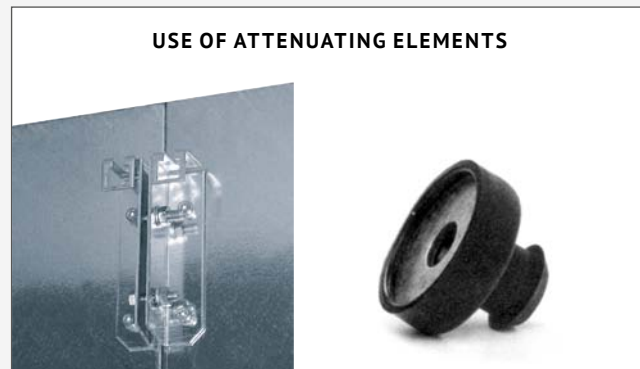

We recommend suspending the unit by means of attenuating elements (they are not a delivery component).

## CONNECTING OF THE DUCTWORK



The connecting of the air-handling ductwork must be done with the help of an elastic connection that prevents the transmission of vibration and eliminates an eventual incongruity of the duct canal and the outlet opening from the unit.

## MEDIA CONNECTION



During assembly, all connections (water, freon etc.) must be done on the external side of the unit. The internal connection is done during manufacture. The appropriate connecting spots are designated by plates.

## UNIQUE SIDE VARIABILITY FOR CONNECTIONS AND ACCESSES

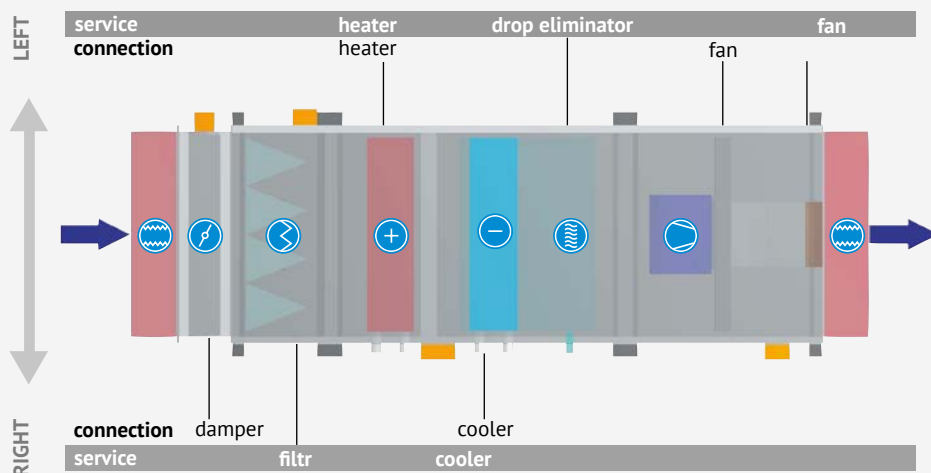

The construction of the units makes it possible to combine the sides for the power connections and service accesses.

### MEANING OF SYMBOLS

- attenuating insert
- air valve
- air filter
- heater
- cooler
- drop eliminator
- fan

# CONSTRUCTION OF UNITS

## MODULE

The module of the FP unit (310 mm) is a basic length parameter. The length of a section or co-section is always its multiple.

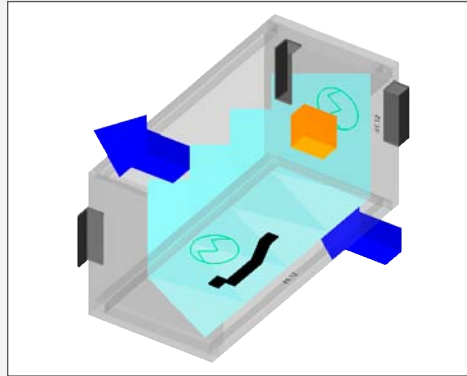

## SECTION

A section is the basic constructional element of AeroMaster FP units.

An insert, i.e. an active element (fan, heater, cooler etc.) is located inside a section.

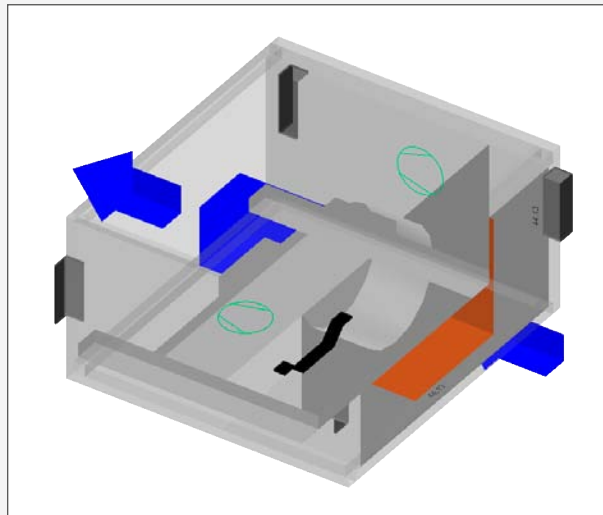

## CO-SECTION

A co-section is a multi-functional block with the best possible joining of sections into a whole.

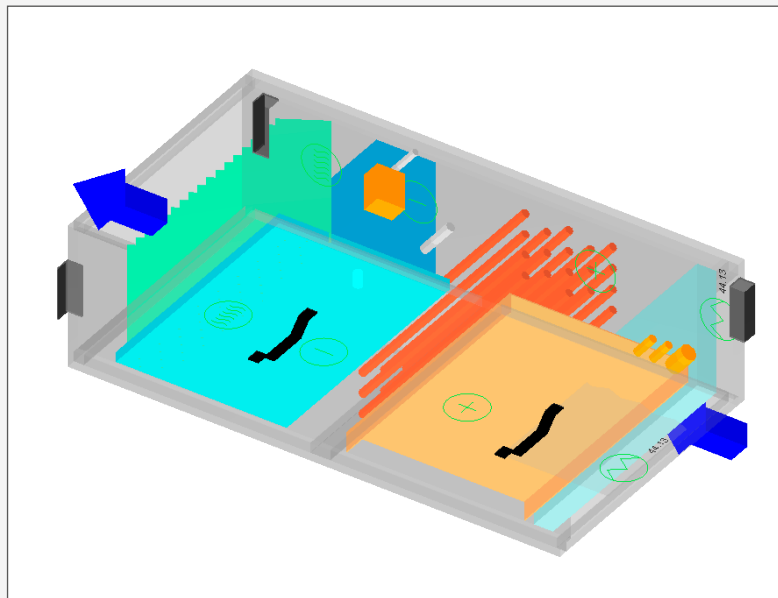

# JOINT ARRANGEMENT

AeroMaster FP air-conditioning units can be put together in a variety of ways so that they suit the conditions given by the place of installation. In the standard version, the inlet and outlet part can be put together in the variations: separately, one behind the other, next to each other. An atypical arrangement can be realized on the basis of a suitable specific offer.

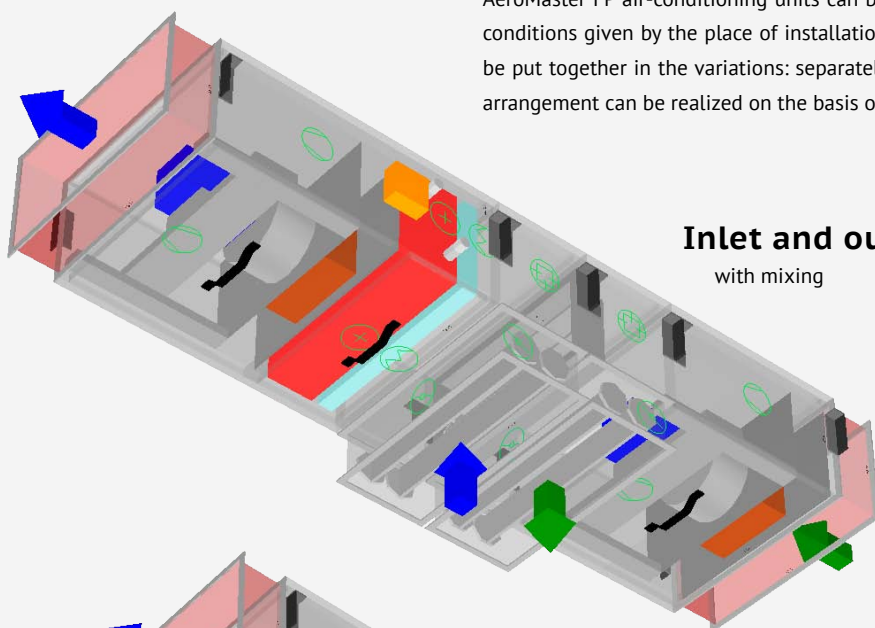

**Inlet and outlet, ONE BEHIND THE OTHER**  
with mixing

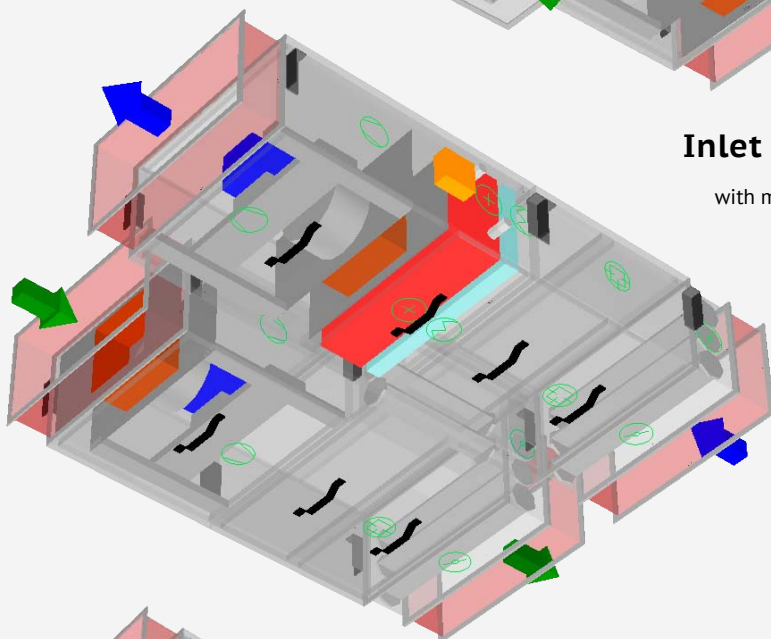

**Inlet and outlet, NEXT TO EACH OTHER**  
with mixing



with heat recovery



# EXAMPLES OF COMPOSITIONS

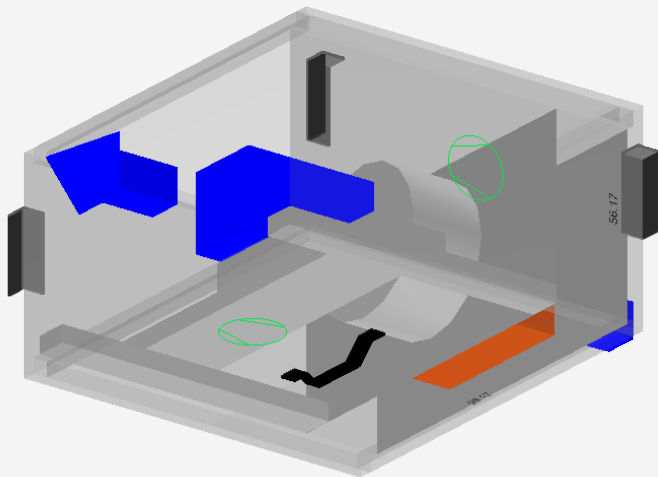

## COMPOSITION 1

fan section		
total length:	620	mm
weight:	46	kg

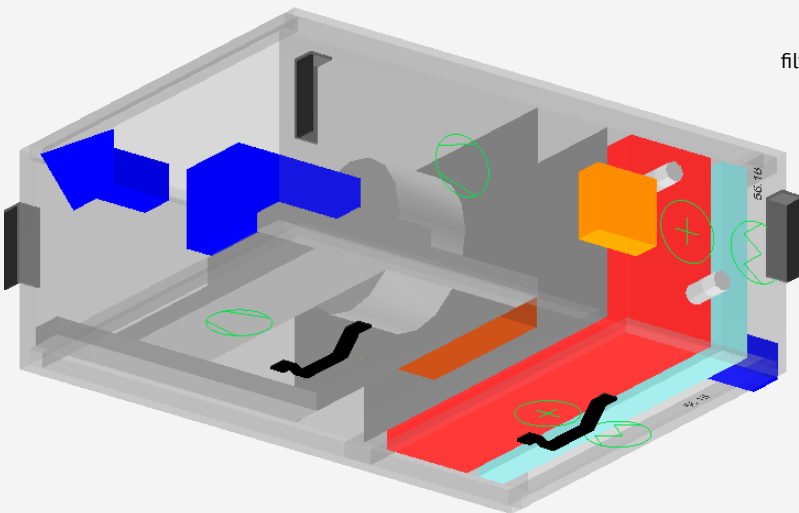

## COMPOSITION 2

filter section, water heater, fan		
total length:	930	mm
weight:	65	kg

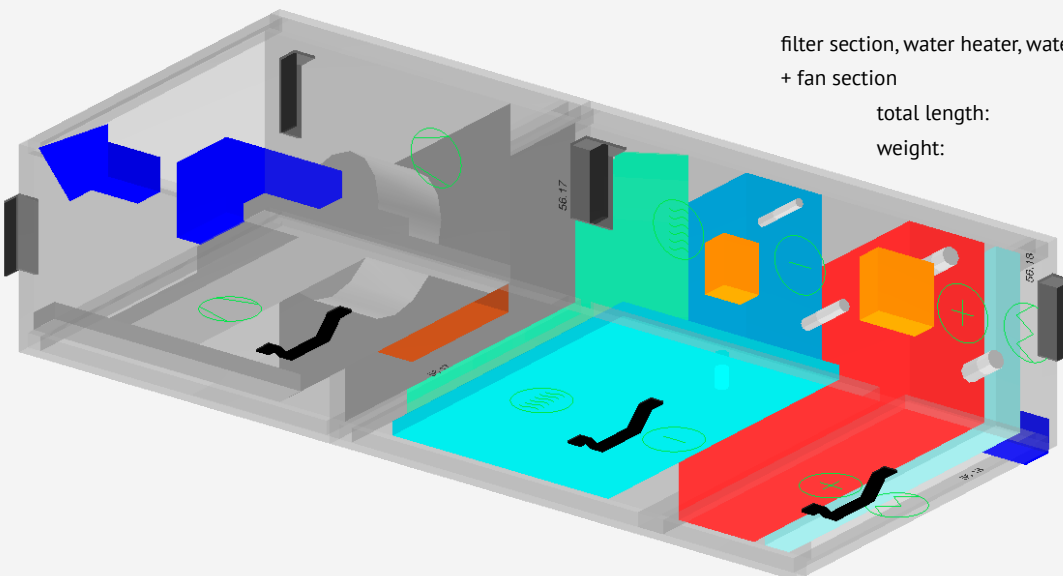

## COMPOSITION 3

filter section, water heater, water cooler, drop eliminator + fan section		
total length:	1550	mm
weight:	102	kg



# EXAMPLES OF COMPOSITIONS

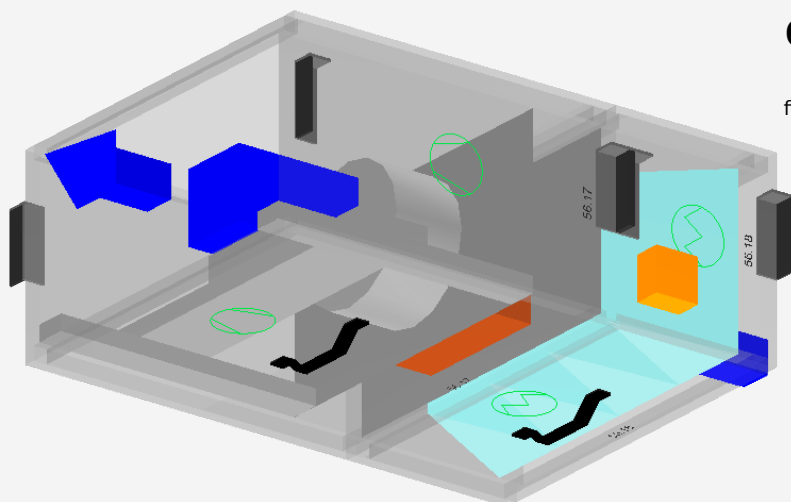

## COMPOSITION 4

filter section + fan section		
total length:	930	mm
weight:	62	kg

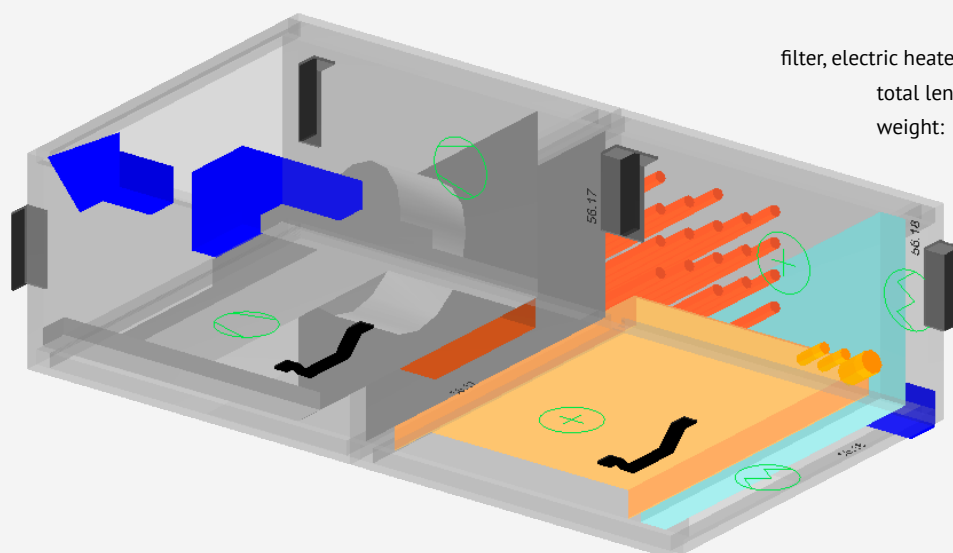

## COMPOSITION 5

filter, electric heater, fan section		
total length:	1240	mm
weight:	84	kg

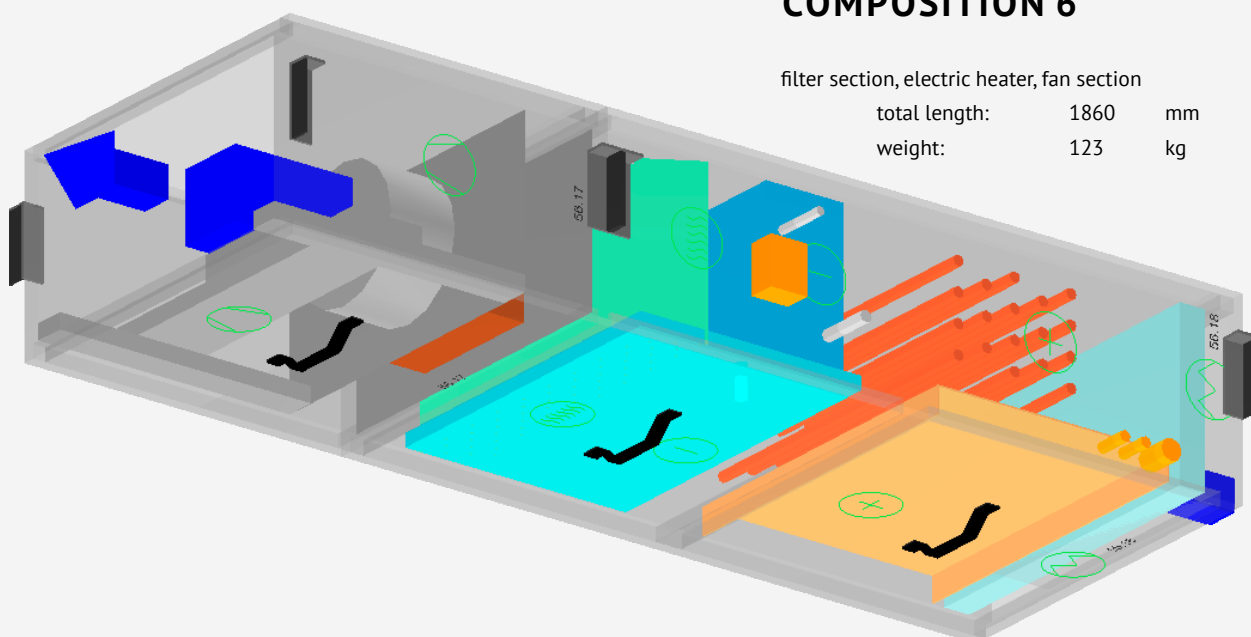

## COMPOSITION 6

filter section, electric heater, fan section		
total length:	1860	mm
weight:	123	kg

# EXAMPLES OF COMPOSITIONS

## COMPOSITION 7

Inlet: mixing section + filter section + water heater, fan sec  
 Outlet: filter section + fan section + mixing section  
 total length: 1860 mm  
 weight: 194 kg

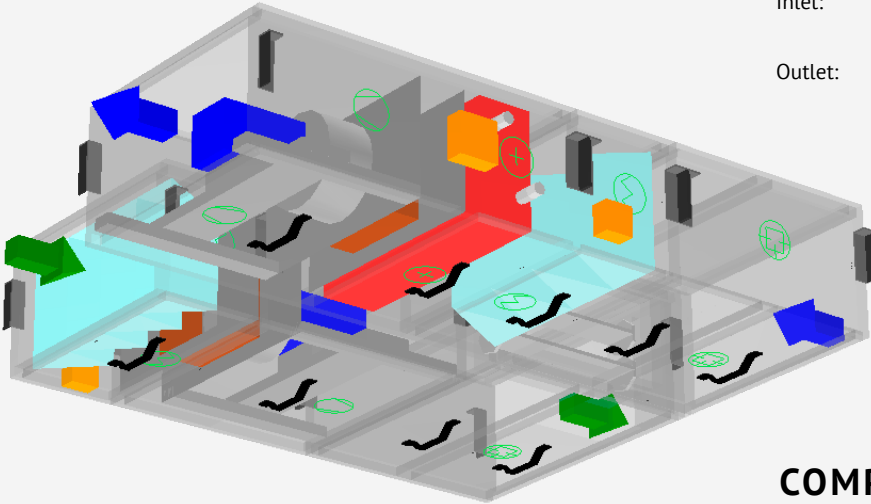

## COMPOSITION 8

Inlet: mixing section + filter section, water heater, fan + diffuser section + filter section  
 Outlet: filter section + sekce fan + mixing section  
 total length: 2790 mm  
 weight: 239 kg

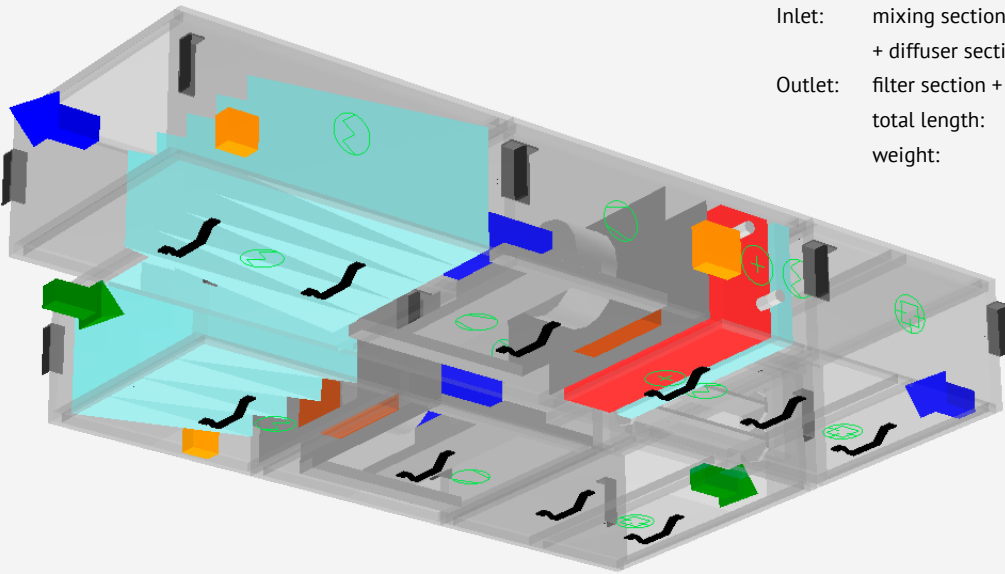

## COMPOSITION 9

Inlet: mixing section + filter section, water heater, freon cooler, drop eliminator + sekce fan  
 Outlet: filter section + fan section + mixing section  
 total length: 2170 mm  
 weight: 216 kg

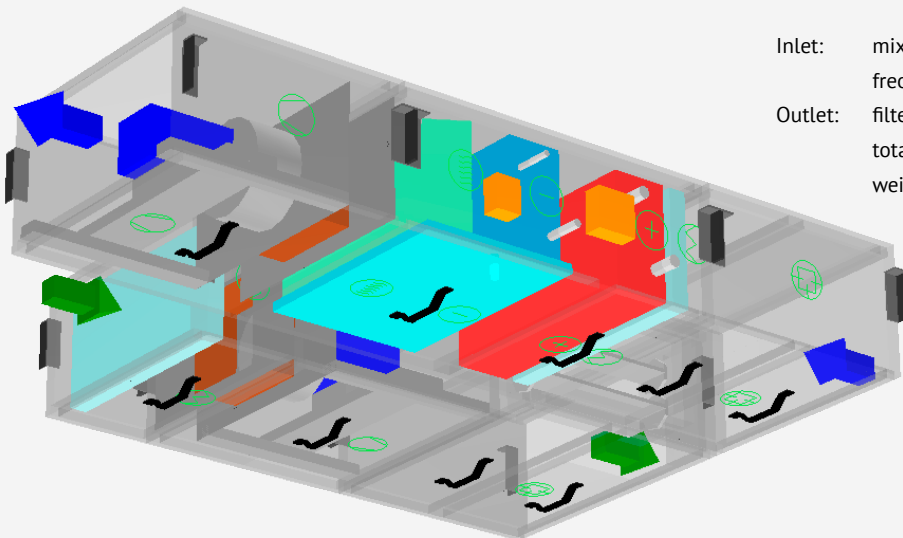

# EXAMPLES OF COMPOSITIONS

## COMPOSITION 10

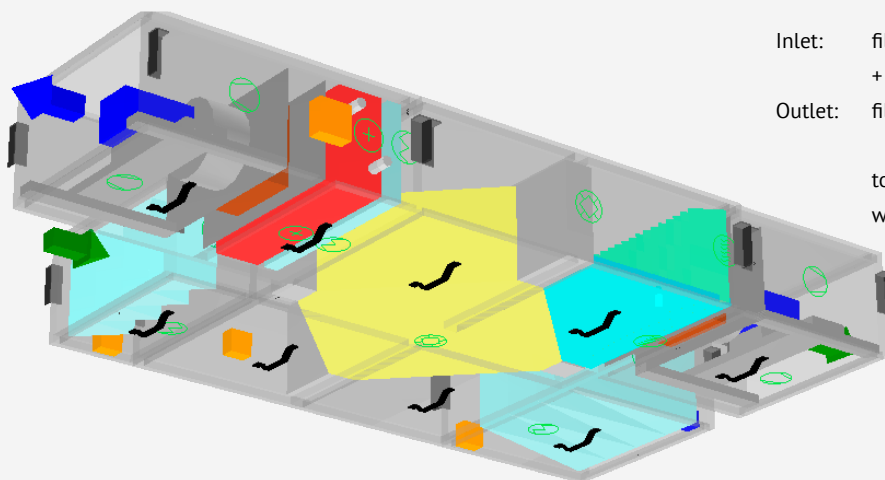

Inlet: filter section + heat-recovery section, bypass  
+ sekce water heater, fan

Outlet: filter section + heat-exchanger section, eliminátor  
kapek + sekce fan

total length: 2790 mm

weight: 285 kg

## COMPOSITION 11

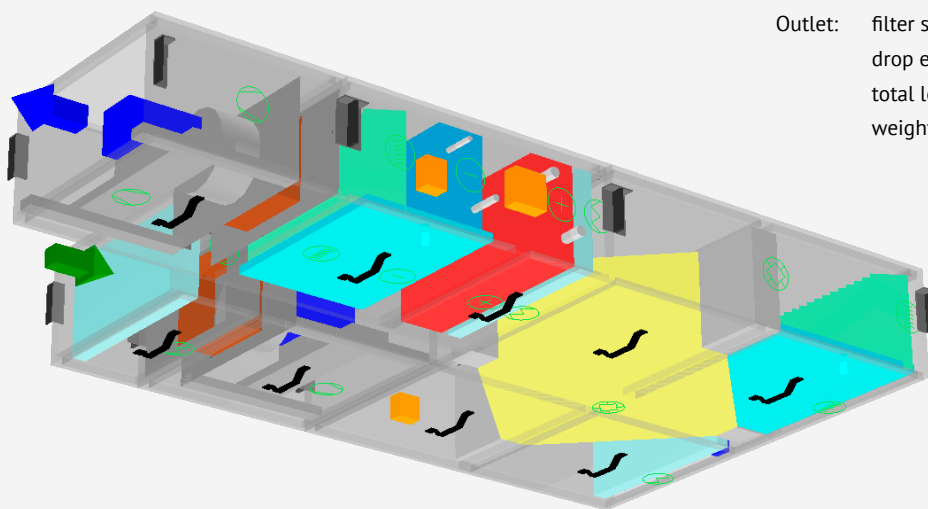

Inlet: heat-recovery section, filtr, bypass + sekce water heater,  
water cooler + fan section

Outlet: filter section + sekce fan + heat-recovery section,  
drop eliminator

total length: 2790 mm

weight: 300 kg

## COMPOSITION 12

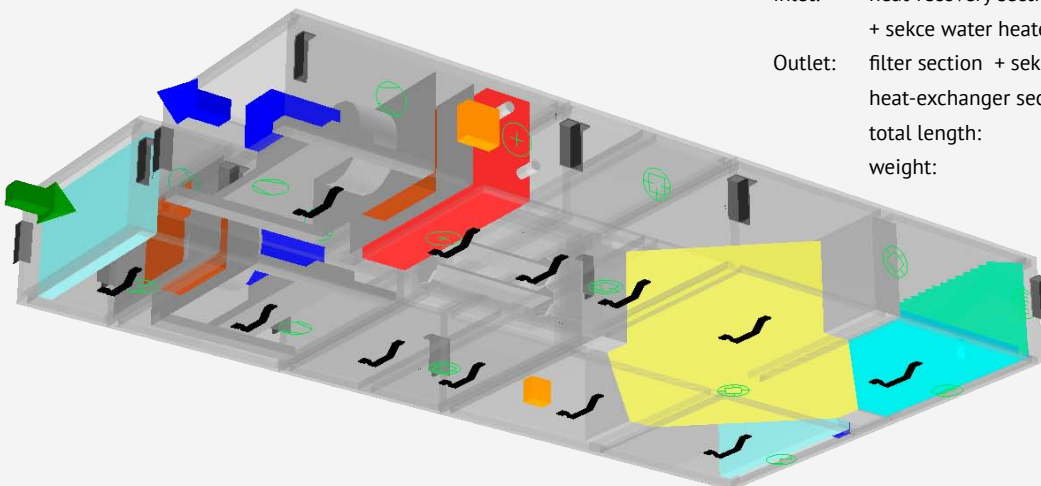

Inlet: heat-recovery section, filtr, bypass + mixing section  
+ sekce water heater, fan

Outlet: filter section + sekce fan + mixing section +  
heat-exchanger section, drop eliminator

total length: 2790 mm

weight: 315 kg



## FPSA FAN SECTION

### CHARACTERISTICS

Fan with overhung impeller.

### PARAMETERS

Electric voltage:

- 3 × 400 V / 50 Hz

Wiring:

- up-to 3 kW 230 VD / 400 VY
- above 3 kW 400 VD / 690 VY

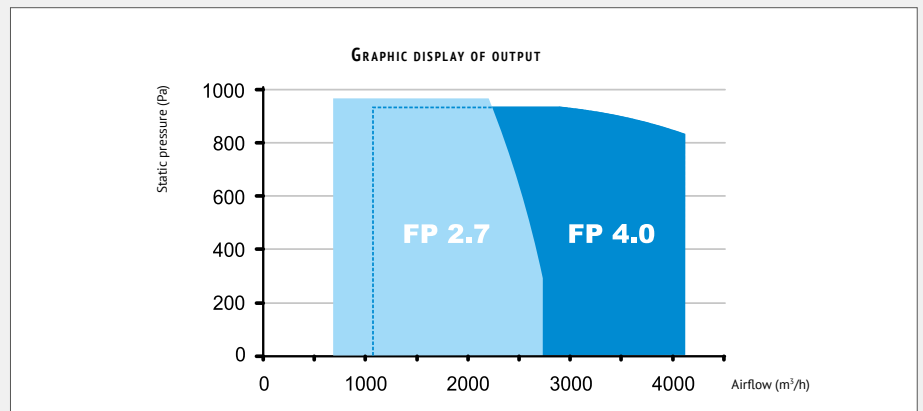

### CONSTRUCTION, TYPE AND MATERIAL VARIATIONS

Impeller:

- An overhung impeller with backward curved blades made of sheet steel
- A steel diffuser on the inlet side.

Motor:

- Single-speed asynchronous motors with a short-circuit armature.

Transmission mounting:

- The impeller is mounted on the motor's shaft. The motor is mounted on a base which is connected to the casing using anti-vibration silent-blocks.

### CONTROL AND PROTECTION

Protective elements:

- As standard, these motors are equipped with thermo-contacts in the winding.

Control:

- The motors must be controlled using frequency inverters to achieve the working point.

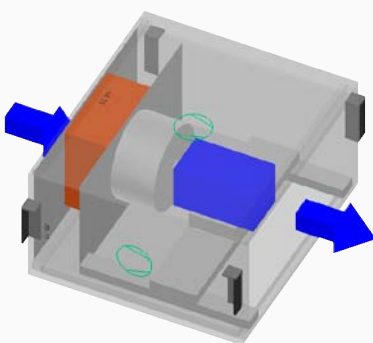

## FPSG DIFFUSER SECTION

### CHARACTERISTICS

The diffuser section is located behind the fan section that has a fan with overhung impeller in those cases where a section requiring an even flow throughout the whole cross-section follows in the composition.

### PARAMETERS

Weight including insert (kg):

- |               |      |
|---------------|------|
| ■ FPSG FP 2.7 | 14,5 |
| ■ FPSG FP 4.0 | 19,0 |

### RECOMMENDATION

The diffuser section must be installed behind the FPSA fan section in those cases where, for example, a section with an attenuator, exchanger, filter etc. follows.

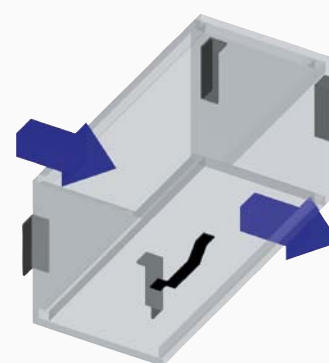

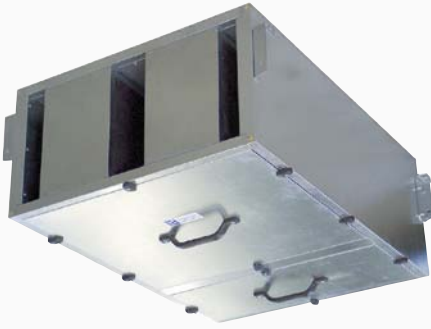

## FPSP NOISE-ATTENUATOR SECTION

### CHARACTERISTICS

The absorption splitter noise attenuators are intended for suppressing the noise that is emitted by the fans on both the intake and exhaust.

Excellent attenuating characteristics, long service life of the splitters.

### PARAMETERS

Weight including insert (kg):

- FPSP FP 2.7/K 49 (short 930mm)
- FPSP FP 4.0/K 68 (short 930mm)
- FPSP FP 2.7/S 68 (medium 1240mm)
- FPSP FP 4.0/S 94 (medium 1240mm)

INSERTED ATTENUATION $D_e$ (dB) AT 250 Hz				
Length of section	930 mm		1240 mm	
Sizes	2,7	4,0	2,7	4,0
Inserted attenuation	16 dB	15 dB	20 dB	20 dB
Number of splitters	2	3	2	3

### CONSTRUCTION, TYPE AND MATERIAL VARIATIONS

- The sections are equipped with TKU splitters. The splitters consist of a moulded frame made of zinc-coated sheet metal and a filling which forms an insulating panel 200 mm thick and which is covered on the sides with an unwoven spun-glass textile.

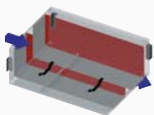
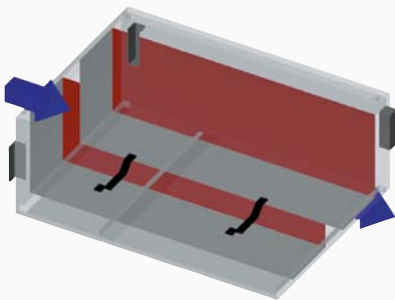

930 mm length

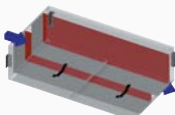

1240 mm length

### RECOMMENDATION

It is possible to provide the noise attenuation also with external attenuators inside the duct.



## FPSH FILTER SECTION – FRAME FILTER

### CHARACTERISTICS

They are intended to be used as fore-filters or as single-stage filtration in less demanding applications. Easy replacement of the filtration insert, low price.

### PARAMETERS

Filtration class:

- G4

Final pressure loss at the nominal flow:

- 250 Pa

Weight including insert (kg):

- FPSH FP 2.7 14,5  
(frame filter)
- FPSH FP 4.0 18,0  
(frame filter)

### CONSTRUCTION, TYPE AND MATERIAL VARIATIONS

- The frame filter is manufactured from folded synthetic filtration material.
- The filtration insert is set into a stiff cardboard frame.

### RECOMMENDATION

- If there is a reduced cross-section in front of the filtration section, we recommend inserting an empty chamber to increase the effective filtration surface.
- Filtration inserts cannot be regenerated.
- When there are large fluctuations in moisture, we recommend checking the stability of the cardboard frame.

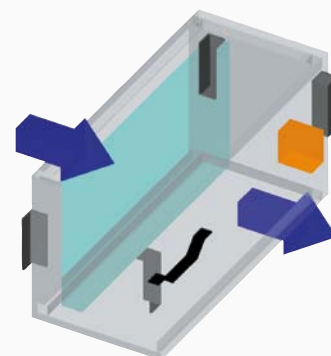



## FPSH FILTER SECTION – BAG FILTER

### CHARACTERISTICS

- Intended for the 1st to 3rd filtration stage depending on the class of filtration textile used.
- Completely tight, large filtration surface, high capacity

### PARAMETERS

Temperature resistance: 70 °C

Třída filtrace:

- Coarse dust filters G3, G4
- Medium dust filters M5
- Fine dust filters F7, F8, F9

Weight including insert (kg):

- **FPSH FP 2.7/K** 13,8 (bag filter)
- **FPSH FP 4.0/K** 18,6 (bag filter)
- **FPSH FP 2.7/S** 23,8 (bag filter)
- **FPSH FP 4.0/S** 30,1 (bag filter)
- **FPSH FP 2.7/D** 33,8 (bag filter)
- **FPSH FP 4.0/D** 45,1 (bag filter)

BASIC PARAMETERS OF FILTERS ACCORDING TO EN 779: 2011			FINAL PRESSURE LOSS (EN 13053: 2006 E)
Filtration class	Mean rate of synthetic dust separation $A_m$ %	Average efficiency $E_m$ for particles 0,4 $\mu m$ %	
G3	$80 \leq A_m < 90$	-	150 Pa
G4	$90 \leq A_m$	-	150 Pa
M5	-	$40 \leq E_m < 60$	200 Pa
F7	-	$80 \leq E_m < 90$	200 Pa
F8	-	$90 \leq E_m < 95$	300 Pa
F9	-	$95 \leq E_m$	300 Pa

310 mm (G3) length

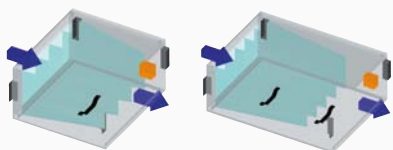
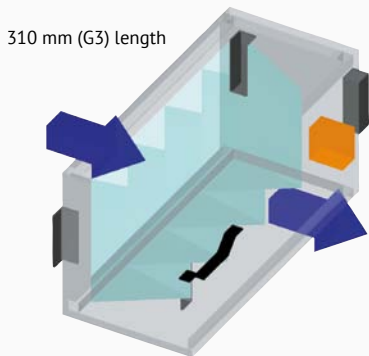

620 mm (G4-M5) length

930 mm (F7-F9) length

### CONSTRUCTION, TYPE AND MATERIAL VARIATIONS

The bag filtration insert is manufactured from synthetic filtration material sewn into pockets in the plastic frame.

### USE

Bag filters of the G3 and G4 class are used as the only filtration stage in less demanding applications or as fore-filters and for the first filtration stage to extract the coarser dust particles.

Bag filters of the M5, F7, F8 and F9 class are used as the second filtration stage; the M5 and F7 class is also used as the only (fine) filtration stage. F8 and F9 filters are always used as the second or sometimes third filtration stage when there are high requirements on the quality of filtration for atmospheric dust.

### MAINTENANCE

Filtration inserts cannot be regenerated.

## FPSH FILTER SECTION – METAL FILTRATION CELL

### CHARACTERISTICS

These filtration sections are frequently used as fore-filters to catch high concentrations of the coarsest dust particles (foundries, smelting works etc.), but their main usage is to catch grease and oil aerosols at the exhaust from bakeries, kitchens, grills etc.

### PARAMETERS

Filtration class:

- G3

Final pressure loss at nominal flow:

- 120 Pa

Weight including insert (kg):

- **FPSH FP 2.7/K** 13,8 (metal filtration cell)
- **FPSH FP 4.0/K** 18,6 (metal filtration cell)

### CONSTRUCTION, TYPE AND MATERIAL VARIATIONS

- The cell is composed of layers of adapted galvanized wires inserted between metal grids. The filter's frame is manufactured from galvanized steel.
- The grease-filter sections are equipped with grease filters of the EU3 filtration class according to DIN 24183; the metal filtration sections form their active part.
- In addition, the grease-filter insert is furnished with a stainless tray to catch the extracted waste particles (greases, oils).
- Easy to clean.

### MAINTENANCE

- The maintenance of the filters consists in removing them from the section and washing in hot water (max. 80 °C) and detergent.
- The stainless tray is affixed to the filter, and it can be cleaned.

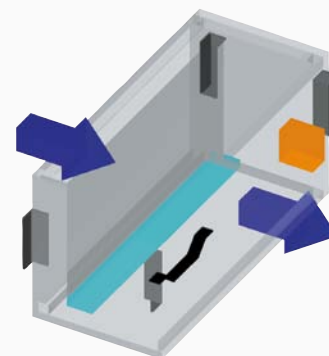



## FPSI MIXING SECTION – SHORT

### CHARACTERISTICS

- It ensures the joint mixing of the inlet and outlet air in the required proportion.
- The mixing can be set in the range of 0–100%.

### PARAMETERS

Weight including insert (kg):

- |                   |     |                |
|-------------------|-----|----------------|
| ■ <b>FPSI 2.7</b> | 8,5 | (short 310 mm) |
| ■ <b>FPSI 4.0</b> | 9,7 | (short 310 mm) |

### CONSTRUCTION, TYPE AND MATERIAL VARIATIONS

- The mixing section consists of a chamber equipped with a system of external dampers that ensure the required manner of mixing.
- The mixings sections are manufactured with variable locations for the dampers.
- You can find more detailed information in the AeroCAD graphic design system.
- The short sections are intended for the installation of the external dampers.
- Short constructional length.

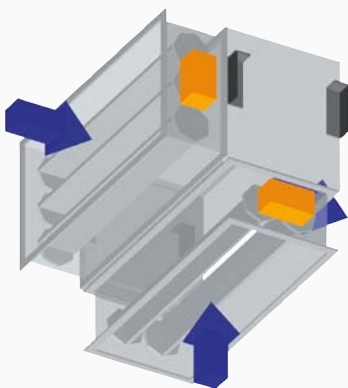

### RECOMMENDATION

In order to control the dampers, it is expedient to order the LM 24X actuator, which has proportional control.

## FPSD MIXING SECTION – LONG

### CHARACTERISTICS

- It ensures the joint mixing of the inlet and outlet air in the required proportion.
- The mixing can be set in the range of 0–100%..

### PARAMETERS

Weight including insert (kg):

- |                   |     |               |
|-------------------|-----|---------------|
| ■ <b>FPSD 2.7</b> | 8,5 | (long 620 mm) |
| ■ <b>FPSD 4.0</b> | 9,7 | (long 620 mm) |

### CONSTRUCTION, TYPE AND MATERIAL VARIATIONS

- The mixing section consists of a chamber equipped with a system of external dampers that ensure the required manner of mixing.
- The mixings sections are manufactured with variable locations for the dampers. You can find more detailed information in AeroCAD.
- The long sections are intended for the installation of the internal and external dampers.
- Easy to clean.

### RECOMMENDATION

In order to control the dampers, it is expedient to order the LM 24X actuator, which has proportional control.

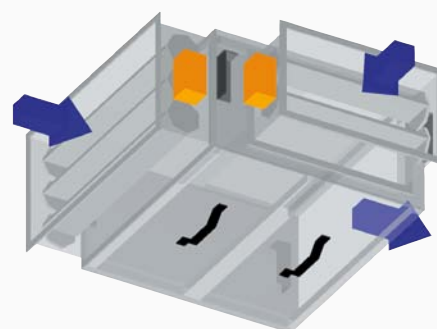

# HEAT RECOVERY



## FPSX PLATE HEAT-EXCHANGER SECTION

### CHARACTERISTICS

- The plate heat exchanger ensures the transmission of heat from the outlet air to the inlet air by means of the large surface of the aluminum exchanger.
- Perfect separation of the inlet and outlet air.

### PARAMETERS

■ Efficiency	up-to 50 %	Weight including insert (kg):	
■ Max. airflow velocity	3 m/s	■ FPSX 2.7	129
		■ FPSX 4.0	175

ENERGY SAVINGS IN DEPENDENCE ON THE EFFICIENCY OF THE HEAT EXCHANGER

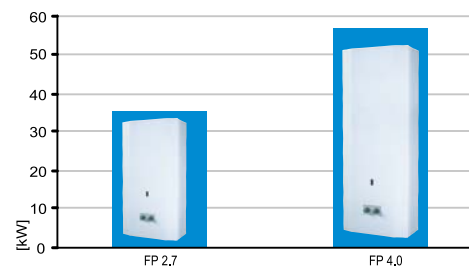

### CONSTRUCTION, TYPE AND MATERIAL VARIATIONS

Heat-transmission surface:

- The plate exchanger is made of aluminum vanes.  
The section is delivered in a version with a bypass and is furnished with a bypass damper.
- The section is equipped with a tray for draining off the condensate, the outlet of which ends with a G 1/2" thread for mounting the siphon.

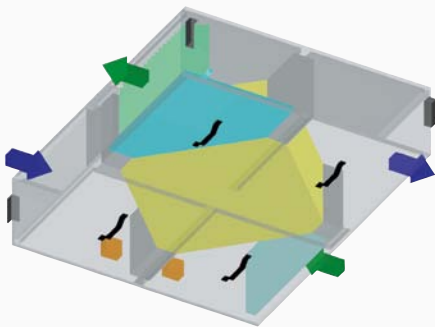

### RECOMMENDATION

It is always expedient to equip the section with removable drop eliminators. In front of the heat exchanger, it is always necessary to install a filter which protects the heat-transmission insert from contamination.



## FPSO DOUBLE SECTION – FILTER (FRAME)

### + EL. HEATING

#### CHARACTERISTICS

- The filtration insert is easy to replace.

#### PARAMETERS

Power supply:

- 3 × 400 V / 50 Hz

Min. airflow velocity:

- 1,5 m/s

Electric protection:

- IP 44

Weight including insert (kg):

- **FPSO 2.7** (12kW – EOS)
- **FPSO 4.0** (22kW – EOS)

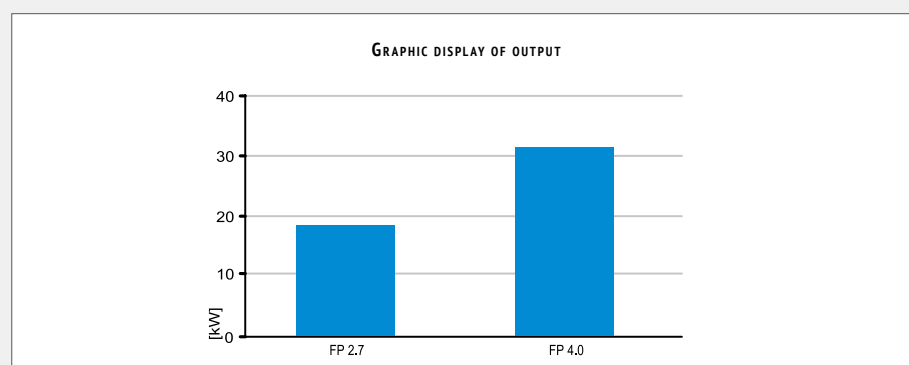

OUTPUTS					
Sizes	Output of heating rods (kW)	Output of inserts EO, EOS (kW)			
FP 2.7	1	6	12	18	–
FP 4.0	1,5	7,5	13,5	22,5	31,5
Sizes	Output of heating rods (kW)	Output of inserts EOSX (kW)			
FP 2.7	1	–	12 (6+6)	18 (6+12)	–
FP 4.0	1,5	–	13,5 (4,5+9)	22,5 (4,5+9+9)	31,5 (9+9+13,5)

#### CONSTRUCTION, TYPE AND MATERIAL VARIATIONS

Heat-transmission surface:

- Heat transmission is provided by coiled stainless heating rods that have a large heat-transmission surface.

Připojení:

- Connection is made easy by connecting the power-supply cable to the prepared terminals in the wiring box.

Variations:

- EO – contactor switching
- EOS – emi-conductor switching
- EOSX – switching by sections

#### CONTROL AND PROTECTION

Protection elements:

- The heaters are furnished with two-stage protection by means of independent thermostats.
- REMAK control units provide ideal control.

#### RECOMMENDATION

The heat-transmission surface must be protected from contamination by a filter.

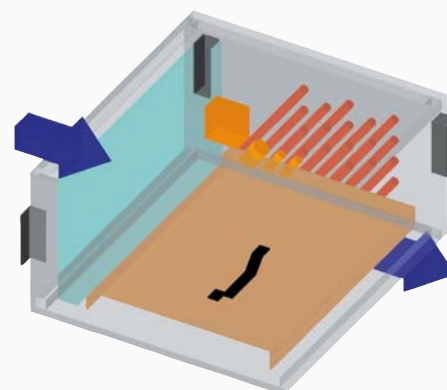

# CO-SECTION



## FPSY DOUBLE SECTION – WATER COOLER + ELIMINATOR

### CHARACTERISTICS

- Stainless tray with G1/2" condensate outlet

### PARAMETERS

- Pressure of cooling water max. 1,6 MPa

Weight including insert (kg):

- **FPSY 2.7** 35,2 (3-row. CHV)
- **FPSY 4.0** 46,9 (3-row. CHV)

GRAPHIC DISPLAY OF OUTPUT

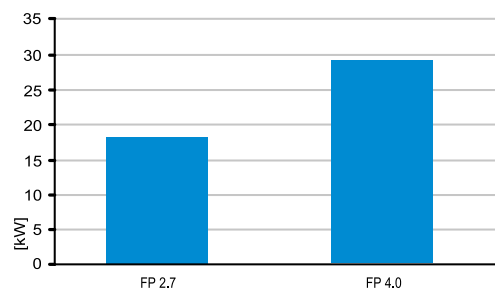

### CONSTRUCTION, TYPE AND MATERIAL VARIATIONS

Heat-transmission surface:

- The water cooler forms the insert. Aluminum vanes, which are put onto copper tubes and overlapped, form the heat-transmission surface.

Connection:

- Connection of the water cooler: G 1" thread
- The section is equipped with a stainless tray and a condensate outlet.

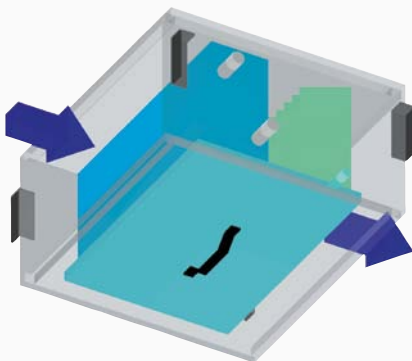

### RECOMMENDATION

The heat-transmission surface must be protected from contamination by a filter.

## FPSY DOUBLE SECTION – DIRECT COOLER + ELIMINATOR

### CHARACTERISTICS

- Stainless tray with G1/2" condensate outlet

### PARAMETERS

Coolant:

- Standard R407
- Upon request R410 etc.

Weight including insert (kg):

- **FPSY 2.7** 35,7 (3-row. CHF)
- **FPSY 4.0** 47,2 (3-row. CHF)

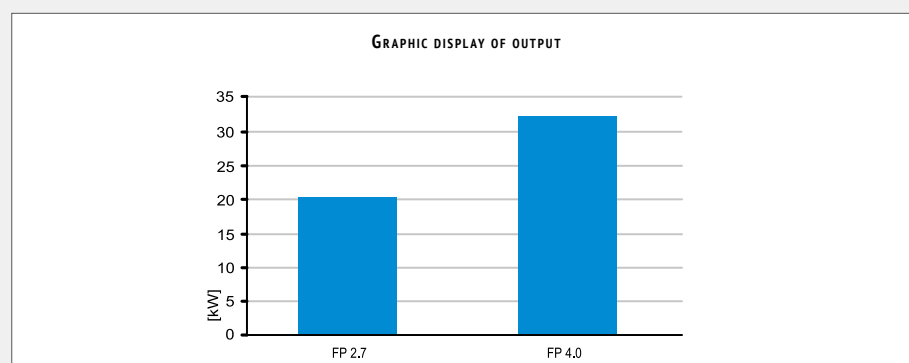

### CONSTRUCTION, TYPE AND MATERIAL VARIATIONS

Heat-transmission surface:

- The direct cooler forms the insert. Aluminum vanes, which are put onto copper tubes and overlapped, form the heat-transmission surface.

Connection:

- The direct cooler is filled with a protective nitrogen atmosphere.
- The section is equipped with a stainless tray and a condensate outlet.

### RECOMMENDATION

The heat-transmission surface must be protected from contamination by a filter.

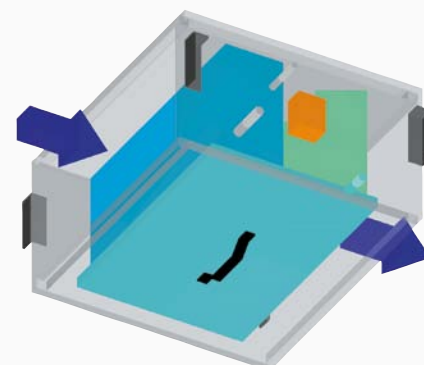

# CO-SECTION



## FPSC CO-SECTION – FILTER (FRAME) + WATER HEATING + FAN

### CHARACTERISTICS

- The multi-functional mono-block makes easy and fast installation possible.

### PARAMETERS

■ Max. temperature of heating water.	110 °C	Weight including insert (kg):	
■ Max. pressure of heating water	1,5 MPa	■ <b>FPSC 2.7</b>	76,7 (for a motor with a stroke height of 90mm, 3-row VO)
		■ <b>FPSC 4.0</b>	106,2 (for a motor with a stroke height of 100mm, 3-row VO)

GRAPHIC DISPLAY OF OUTPUT

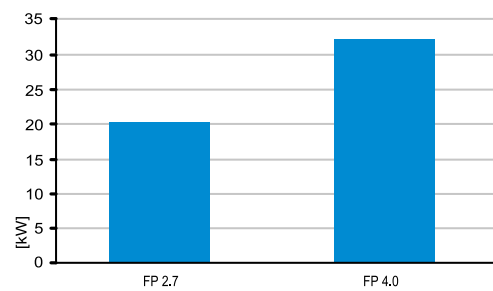

### CONSTRUCTION, TYPE AND MATERIAL VARIATIONS

- The outer casing of the exchangers is manufactured from zinc-coated sheet metal.
- The water heaters are made of Cu tubes with a diameter of 12 mm (geometry) upon which Al vanes are put and overlapped with a spacing of 2.1 mm.
- The collectors and connecting necks are welded from steel pipes.
- All heaters are tested for air-tightness at a pressure of 3.6 Mpa under water at a temperature of 10–30 °C.

### CONTROL AND PROTECTION

- As standard equipment, the water heaters have TACO self-de-aeration valves.
- The SUMX mixing set can added.

### RECOMMENDATION

- Always install the filter in front of the heater.

### RECOMMENDED ACCESSORIES

- NS 130 anti-freeze feeler.
- SUMX mixing set.

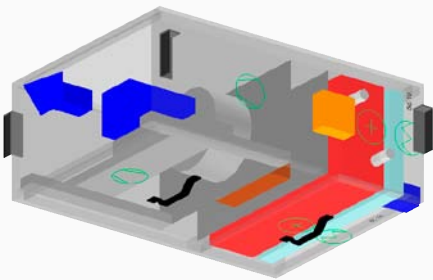

## FPSE CO-SECTION – FILTER (FRAME)

### + EL. HEATING + FAN

#### CHARACTERISTICS

- The multi-functional mono-block makes easy and fast installation possible.

Weight including insert (kg):

- **FPSE 2.7** 96,5 (for a motor with a stroke height of 90mm, 12kW EOS)
- **FPSEC 4.0** 132,0 (for a motor with a stroke height of 100mm, 22kW EOS)

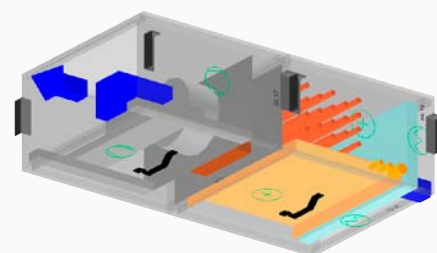

## FPSV CO-SECTION - FILTER (FRAME)

### + WATER HEATING + COOLER + ELIMINATOR

#### CHARACTERISTICS

- The multi-functional mono-block makes easy and fast installation possible.

Weight including insert (kg):

- **FPSV/V 2.7** 53,4 (3-row VO, CHV)
- **FPSV/V 4.0** 73,1 (3-row VO, CHV)



Co-section with direct evaporator

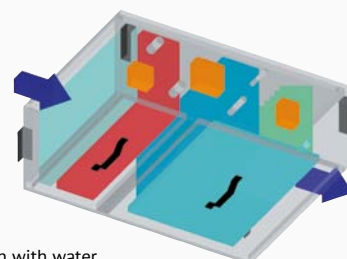

Co-section with water cooler

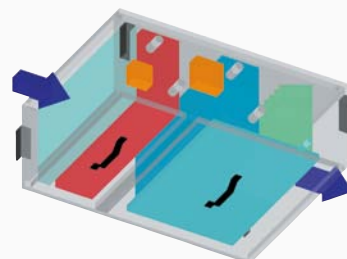

# Co-SECTION



Co-section with direct evaporator

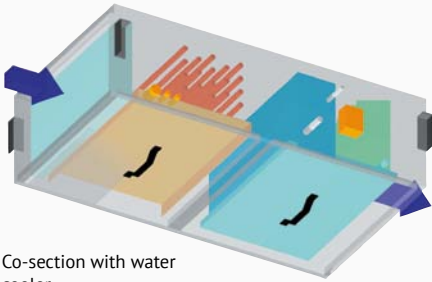

Co-section with water cooler

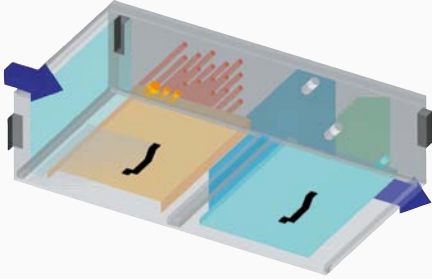

## FPSW CO-SECTION – FILTER (FRAME) + ELECTRIC HEATING + COOLER + ELIMINATOR

### CHARACTERISTICS

- The multi-functional mono-block makes easy and fast installation possible.

Weight including insert (kg):

- **FPSV/F 2.7** 53,9 (3-row VO, CHF)
- **FPSV/F 4.0** 73,4 (3-row VO, CHF)

# SNADNÝ PŘÍSTUP K NABÍDCE

## YOU HAVE A CLEAR REQUIREMENT...

### Contact us:

- Tel: 00420 571 877 778
- Fax: 00420 571 877 777

e-mail: [export@remak.cz](mailto:export@remak.cz)



## DO YOU WISH TO CONSULT YOUR DESIGN WITH US?

- Contact your personal consultant in REMAK – [www.remak.cz](http://www.remak.cz)
- We will design your unit together in your office.

... PROMPT DESIGN DURING PERSONAL MEETING



## DO YOU WANT THE UNIT TO BE MADE-TO-MEASURE?

- Order your AeroCAD Professional design program.
- Register as an AeroCAD Professional program user.
- Create required unit, and send it to the following address: [aerocad@remak.cz](mailto:aerocad@remak.cz)

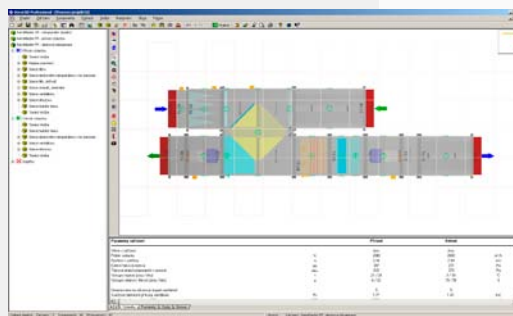
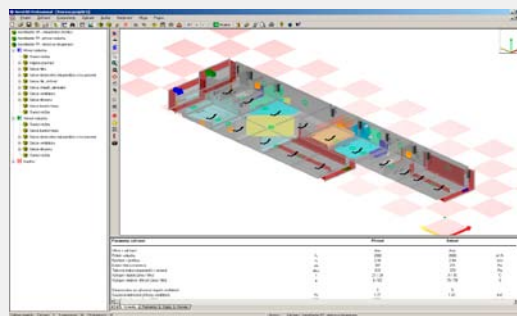

## ...IMMEDIATELY AVAILABLE TECHNICAL PARAMETERS AND THE PRICE BY RETURN



This Catalogue (as a whole or a part) must not be printed or copied without prior written permission from REMAK a. s., Zuberská 2601, Rožnov pod Radhoštěm, Czech Republic.

This „Catalogue“ are the sole property of REMAK a. s.

Changes reserved.

Issued: 20<sup>th</sup> March, 2013

Technical data updated on 20<sup>th</sup> March, 2013. Printing and language mistakes are reserved.





REMAK a.s.  
Zuberská 2601  
756 61 Rožnov pod Radhoštěm  
Czech Republic  
tel.: +420 571 877 778  
fax: +420 571 877 777  
[www.remak.eu](http://www.remak.eu)

