



VFL, VFLPG, VTL and VRA
Rectangular electric duct heaters



VFL, VFLPG, VTL and VRA

Rectangular electric duct heaters

VEAB rectangular duct heaters are available in ratings of up to 2000 kW and are used for heating the supply air in duct systems, in central air handling units and for various industrial processes. If correctly rated, rectangular duct heaters can provide heating for entire houses and buildings. Our flexible production system enables us to adapt the duct heaters accurately to the application. This may concern heaters for air handling units, industrial processes or very tough environments. This may involve the need for reinforced electrical insulation, the use of stainless steel, high power ratings, high operating temperatures or the like.

- Power ratings from 0.5 kW to 2000 kW
- Degree of protection IP43 as standard, IP55 or IP65 to special order.
- With built-in regulator or for external control
- Can be installed both horizontally and vertically
- Built-in overheating protections, at least one with automatic reset and one with manual reset
- Enclosed stainless steel tubular heating elements

Standard design

The casing is made of Aluzinc-coated sheet steel, AZ 185, that conforms to the requirements for corrosivity class C4. The heater elements are made of stainless steel to EN 1.4301. The junction box includes the terminal blocks necessary for the electrical connections.

The casing is available in four versions. See page 6 for more detailed information. The duct heaters are produced to degree of protection IP43, but are also available to IP55 or IP65 to special order. The heaters are adapted for max 50°C outgoing temperature and a min. air velocity of 1.5 m/s.

Overheating protection

All duct heater models have at least two overheating protections – one with automatic reset and one with manual reset. All duct heaters have the overheating protection reset button on the heater cover.

Alarm relay, designation suffix –L

All models can be equipped with a built-in relay with potential-free alarm contacts that indicate tripping of the manually resettable overheating-protection. The alarm relay is included as standard in models -MQXL, -MTXL, -MQYL, -MTYL, -MQCL, -MTCL, -MQEML and -MTEML



Electronic flow monitor

Built-in electronic air flow monitor is available for all models with built-in control equipment and for max 40A 3-phase (e.g max 27 kW, 3x400V).

The flow monitor continually monitors the air flow and shuts down the heater if the air velocity should drop below 1.5 m/s, thus avoiding overheating. When the air velocity again exceeds 1.5 m/s, the heater will automatically be switched on. This means that heaters with built-in flow monitor meets the requirements for interlocking with the fan/air flow and can be installed without any external interlocking. This ensures very simple installation.

Approvals

The heaters with ratings up to and 200 kW, have been tested and approved by Intertek SEMKO in accordance with:
LVD Directive: EN 60355-1 and EN 60335-2-30

EMC Directive: EN 61000-6-2, EN 61000-6-3 and EN 61000-6-1

EMF Directive: EN 62233

Heaters with ratings 200 kW and below are provided with S and CE marking.

Heaters with ratings above 200 kW are provided with CE marking.



Control

Built-in regulator

A built-in regulator ensures simple installation, e.g. due to fewer cable runs, which lowers the installation cost and reduces the risk of incorrect wiring. The regulator is electronic and controls the output across a triac by means of time proportional control (intermittent ON/OFF control). This provides very accurate temperature control. Since control is electronic, it is entirely silent and sustains a minimum of wear. On heaters with higher ratings, parts of the output are controlled by a step controller. However, fine adjustment of the temperature is always carried out by the electronic ON/OFF control.

The following models are available with built-in regulator:

-MQEML / -MTEML, for one or two sensors

Duct heater with built-in temperature regulator, for room or duct sensor. Can also be connected to a main sensor in the room and a min./max. sensor in the supply air. See page 8.

-MQXL /-MTXL, for 0...10V control signal

Duct heater with built-in regulator, for external 0...10V control signal. See page 10.

-MQYL / -MTYL, for 2...10V control signal

Contact VEAB for more information.

-MQCL / -MTCL, for 4...20mA control signal

Contact VEAB for more information.

External regulator

Our duct heaters can be specified without built-in regulator and an external regulator must then be added. The following model is available for external regulator:

-M(L)

The duct heater is equipped with an external temperature regulator or thermostat. See page 12.

Options other than standard version

In addition to the standard design, several options are available for matching to your specific application.

Other materials

The casing can be made of stainless steel, EN 1.4301, or of acid-resistant stainless steel, EN 1.4404.

Duct heater for outlet temperatures of 51°C - 120°C

The overheating protection is matched to the operating temperature. The junction box is provided with 25 mm thick insulation on the duct side.

Duct heater for outlet temperatures of 121°C - 400°C

Casing of hot-rolled sheet steel or stainless steel. The overheating protection is matched to the operating temperature. The junction box is provided with 100 mm thick insulation on the duct side. An air gap is provided between the duct and the junction box. Degree of protection IP30.

Reinforced electrical insulation

In order to avoid leakage currents to earth, the elements are mounted on electrically insulating material. Suitable in, for instance, marine applications, when it is difficult to provide electrical connection to earth.

Signal lamp

Used with the manual overheating protection and/or as an operation indicator.

Lifting lugs

Duct heaters can be provided with lifting lugs to facilitate mounting.

Modbus

The duct heaters may be equipped with Modbus communication. Contact VEAB for further information.

Degree of protection IP55 / IP65

Duct heaters can be produced to degree of protection IP55 or IP65 instead of the standard IP43 version.

Heater in the junction box

A heater is advisable for use during stoppages, e.g. in humid environments, in order to avoid admission of moisture at the element ends, or to reduce the risk of condensation in the junction box when cold air is flowing in the duct.

Circular connection

If the output needed or the connection diameter exceeds what is available in the standard range of our CV circular duct heaters, rectangular duct heaters can be produced with circular connections.

Non-standard supply voltages

Heaters can be manufactured with non-standard supply voltages up to 690V3~ for external control and 500V3~ for built-in control.

Built-in main switch

Available only for models with built-in control equipment.

Product range overview

Our rectangular duct heaters are available in four versions, designed to suit different methods of installation. The width and height are selected to suit the width and height of the duct or unit in which the heater is to be fitted. The minimum air velocity of 1.5 m/s must also be taken into account.

	Dimensions	
	Min.	Max.
Width, B	200 mm	3000 mm
Height, H	200 mm	3000 mm
Depth, D	270 mm	
	(standard for D = 370 mm)	

Air pressure drop across the duct heater

The pressure drop of the air flowing through the duct heater is dependent on the air velocity and the number of heater element rows in the heater. The approximate number of heater element rows can be calculated from the following formula:

$$X = \frac{P}{A \times 15}$$

X = number of element rows
 A = flow area of duct heater, $W \times H$, m^2
 P = total power, kW

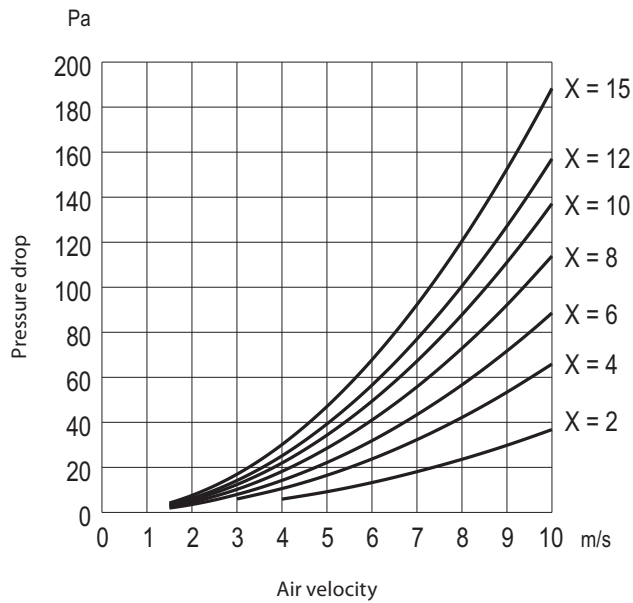

Installation

The duct heaters can be installed in horizontal or vertical ducts. The air flow through the duct heater must be in the direction of the arrow on the duct heater cover. In horizontal duct runs, the junction box may face either right or left. Installation with junction box facing upwards or downwards is not allowed. The duct heater must be mounted so that the air flow will be uniform throughout the cross-sectional area. We recommend that the distance to or from a duct bend, fan, damper, etc. should be at least the same as the diagonal dimension of the duct heater, i.e. from corner to corner at the connection face of the heater.

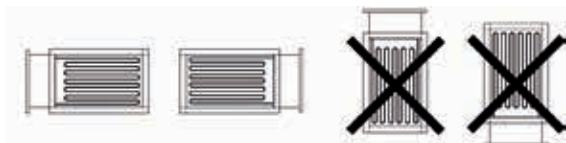

Interlock with fan/air flow rate

Electric duct heaters must always be installed so that they are interlocked either with the fan that delivers air into the duct or with the air flow rate through the heater. The power supply to the duct heater must be interrupted when the fan is tripped or if the air flow should cease. For heaters rated above 30 kW, it is recommended that the fan should be left running for at least 3 minutes after the power supply has been switched off.

The models with built-in electronic air flow monitor conform to the requirement for interlocking with the fan/air flow rate and can be installed without external interlocking.

The circuit boards of -MTEML and -MTXL models rated up to 27 kW, 3-phase, 400V are provided with a terminal for connecting a pressure or flow monitor. Heaters rated above 27 kW should be interlocked via the incoming control circuit. The -M model shall always be interlocked on the incoming power supply.

Heater element surface temperature

The surface temperatures of the heater elements are dependent on the air velocity and the specific surface power of the elements. The specific surface power of the elements is around 3 W/cm². The graph shows the surface temperature of the heater elements when the outlet air temperature of the duct heater is 20°C.

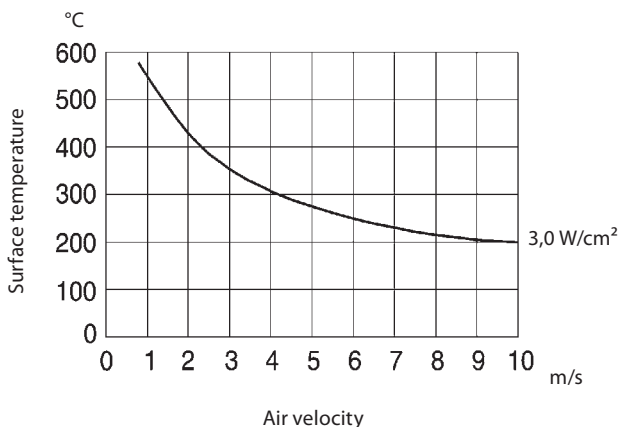

Minimum air velocity and outlet air temperature

The duct heaters are designed as standard for a minimum air velocity of 1.5 m/s and a maximum operating air temperature of 50°C.

Ambient temperatures for duct heaters:
 Without built-in control equipment = 40°C max.
 With built-in control equipment = 30°C max.

The following formula can be used for calculating the air velocity:

$$V = \frac{Q}{3600 \times A}$$

V = air velocity, m/s
 Q = air flow rate, m³/h
 A = cross-sectional area of the air heater (B×H), m²

Power demand

The air flowing through the duct heater is heated in accordance with the following formula:

$$P = Q \times 0,36 \times \Delta t$$

P = power, W
 Q = air flow rate, m³/h
 Δt = temperature rise, °C

Dimensions

VFL - with flanges

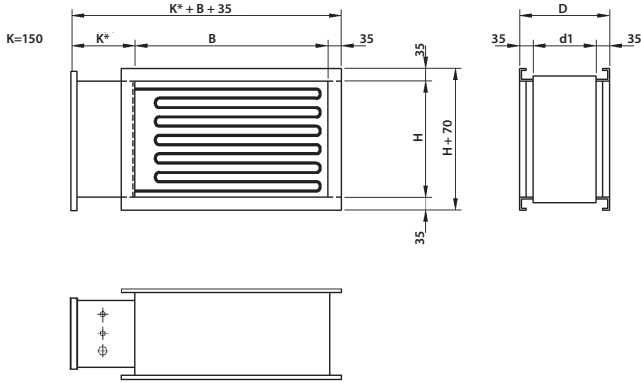

VFLPG - suitable for PG slip clamps

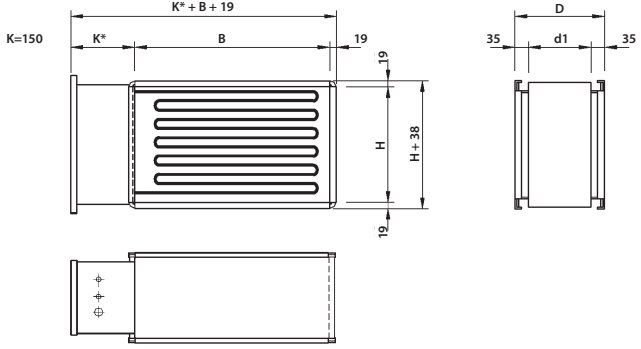

VTL - for insertion mounting in the duct

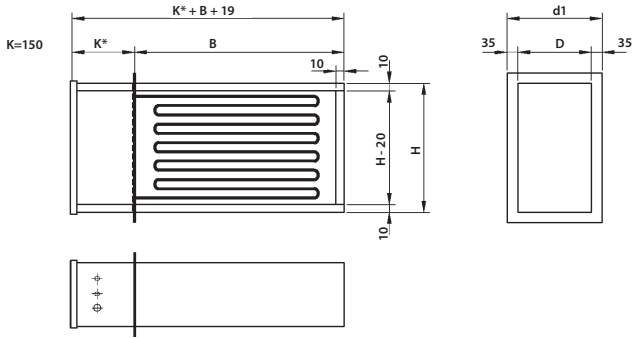

VRA - for air handling unit

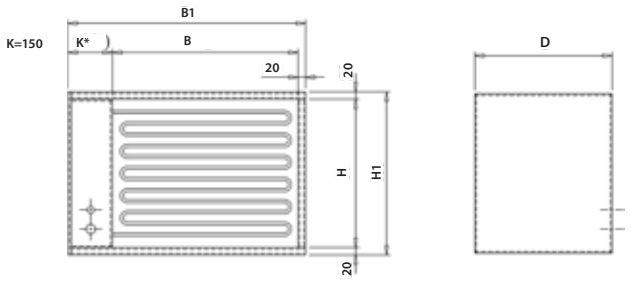

*) The dimension is K=200 mm for duct heaters with built-in control equipment.

VFL / VFLPG / VTL / VRA

Project design/ordering

Versions	VFL – with flanges VFLPG – suitable for PG slip clamps VTL – for insertion mounting in the duct VRA – for air handling unit	
Width, dimension B Height, dimension H	200 mm min., 3000 mm max. 200 mm min., 3000 mm max.	
Total output, kW	Can be selected between 0.5 kW and 2000 kW	
Power supply voltage	1 × 230V = 1-phase, 230V 2 × 400V = 2-phase, 400V 3 × 400V = 3-phase, 400V 3 × 440V = 3-phase, 440V	3 × 230V = 3-phase, 230V 3 × 460V = 3-phase, 460V 3 × 500V = 3-phase, 500V 3 × 690V = 3-phase, 690V
Models	-MQEML / -MTEML -MQXL / -MTXL -MQYL / -MTYL -MQCL / -MTCL -M(L)	Connected to a duct or room sensor, or to the main sensor in the room and a min./max. sensor in the supply air. The output is controlled by an ext. 0...10V control signal. The output is controlled by an ext. 2...10V control signal. The output is controlled by an ext. 4...20mA control signal. For external control equipment.
Casing material	A = Aluzinc, AZ 185 S = Stainless steel, EN 1.4301 SA = Acid-resistant stainless steel, EN 1.4404	
Degree of protection	IP43 / IP55 / IP65	
Electric insulation	NI = Normal electric insulation RI = Reinforced electric insulation	
Outlet air temperature	50C = 50°C max. outlet temperature 120C = 120°C max. outlet temperature	

VFL / VFLPG / VTL / VRA

Type designation VFL-, VFLPG- and VTL-

A type designation of a duct heater may be, for example, VFLPG-1200-500-100-3×400V-M-SA-IP43-NI-50°C, which describes the design of the product. The type designation is made up in accordance with the following model:

Version	Dimension width, B	Dimension height, H	Total output, kW	Power supply voltage, V	Model	Casing material	Degree of protection	Electric insulation	Outlet air temperature.
VFLPG	1200	500	100 kW	3 × 400V	M	SA	IP43	NI	50C

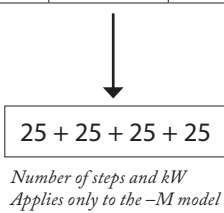

Type designation VRA-

Version	Dimension width, B1	Dimension height, H1	Total output, kW	Power supply voltage, V	Model	Casing material	Degree of protection	Electric insulation	Outlet air temperature.
VRA	1400	540	100 kW	3 × 400V	M	SA	IP43	NI	50C

VFL, VFLPG, VTL and VRA

Rectangular electric duct heaters with built-in control equipment for one or two sensors

Duct heaters with built-in control equipment are ready for installation on delivery. This offers the following benefits:

- Minimum of cable runs – ready-wired control equipment
- Simple installation – reduced installation costs
- Minimized risk of incorrect wiring on installation
- Accurate control

- MQEML

For connection to a duct or room sensor. Alternatively, can be connected to two sensors: one sensor in the room and one min./max. sensor in the supply air. Has potential-free alarm contacts that indicate tripping of the overheating protection with manual reset. The sensors must be ordered separately.

The heater has a built-in electronic air flow monitor (see page 2).
-MQEML can be manufactured up to 40A 3-phase
(27 kW 3×400V)

- MTEML

For connection to a duct or room sensor. Alternatively, can be connected to two sensors: one sensor in the room and one min./max. sensor in the supply air. Has potential-free alarm contacts that indicate tripping of the overheating protection with manual reset. The sensors must be ordered separately.

-MTEML can be manufactured up to 440 kW.

Selecting the output

The total output of the duct heater with built-in control equipment can be selected freely from the entire range between 0.5 kW and 440 kW.



Project design/ordering

Descriptive text for - MQEML

VEAB type VFLPG-800-400-25 kW-3x400V-MQEML-A-IP43-NI-50C duct heater (see page 7), with the casing made of Aluzinc-coated sheet steel, AZ 185 that conforms to the requirements for corrosivity class C4. The heater elements are made of stainless steel to EN 1.4301. Has potential-free alarm contacts that indicate tripping of the overheating protection with manual reset. Has a built-in electronic air flow monitor.

Control by means of built-in temperature regulator for room or duct sensor. Sensor and external set point adjuster must be ordered separately.

Descriptive text for - MTEML

VEAB type VFLPG-1200-500-100 kW-3x400V-MTEML-A-IP43-NI-50C duct heater (see page 7), with the casing made of Aluzinc-coated sheet steel, AZ 185 that conforms to the requirements for corrosivity class C4. The heater elements are made of stainless steel to EN 1.4301. Has potential-free alarm contacts that indicate tripping of the overheating protection with manual reset.

Control by means of built-in temperature regulator for room or duct sensor. Sensor and external set point adjuster must be ordered separately.

Accessories

There are several sensors/set point combinations for the VFL/VFLPG/VTL/VRA - MQEML /- MTEML. For a complete wiring diagram, see the fitting instructions at our homepage www.veab.com (select Products/Duct heaters-Electric).

Room sensor with setpoint adjuster

Alt 1



TG-R430 as set point adjuster and room sensor.

Alt 2



TG-R430 as setpoint adjuster and room sensor.



TG-K360 as min./max. supply air sensor.

Room sensors and separate set point adjustment

Alt 3



TG-R530 (IP30) or TG-R630 (IP54) as room sensor.



TG-R430 as setpoint adjuster.

Alt 4



TG-R530 (IP30) or TG-R630 (IP54) as room sensor.



TG-R430 as setpoint adjuster.



TG-K360 as min./max. supply air sensor

Main sensor in the exhaust air and separate set point adjuster

Alt 5



TG-K330 as exhaust air sensor.



TG-R430 as setpoint adjuster.

Alt 6



TG-K330 as exhaust air sensor.



TG-R430 as setpoint adjuster.



TG-K360 as min./max. supply air sensor.

Supply air sensor and separate set point adjuster

Alt 7



TG-K330 as supply air sensor.



TG-R430 as setpoint adjuster.

Data for all sensors and detailed information about sensors for duct heaters with supply voltage of 415-500V, see page 15.

VFL, VFLPG, VTL and VRA

Rectangular electric duct heaters with built-in control equipment for 0...10V external control signal

Duct heaters with built-in control equipment are ready for installation on delivery. This offers the following benefits:

- Minimum of cable runs – ready-wired control equipment
- Simple installation – reduced installation costs
- Minimized risk of incorrect wiring on installation
- Accurate control

- MQXL

For connection to an external 0...10V control signal. Has potential-free alarm contacts that indicate tripping of the overheating protection with manual reset. The heater has a built-in electronic air flow monitor (see page 2). -MQXL can be manufactured up to 40A 3-phase (27 kW 3×400V)

- MTXL

For connection to an external 0...10V control signal. Has potential-free alarm contacts that indicate tripping of the overheating protection with manual reset. -MTXL can be manufactured up to 440 kW.

Selecting the output

The total output of the duct heater with built-in control equipment can be selected freely from the entire range between 0.5 kW and 440 kW.



Project design/ordering

Descriptive text - MQXL

VEAB type VFLPG-800-400-25kW-3x400V-MQXL-A-IP43-NI-50C (see page 7) duct heater with the casing made of Aluzinc-coated sheet steel, AZ 185 that conforms to the requirements for corrosivity class C4. The heater elements are made of stainless steel to EN 1.4301. Has potential-free alarm contacts that indicate tripping of the overheating protection with manual reset. Has a built-in electronic air flow monitor.

Control by means of built-in regulator for 0...10V control signal.

Descriptive text - MTXL

VEAB type VFLPG-1200-500-100kW-3x400V-MTXL-A-IP43-NI-50C (see page 7) duct heater with the casing made of Aluzinc-coated sheet steel, AZ 185 that conforms to the requirements for corrosivity class C4. The heater elements are made of stainless steel to EN 1.4301. Has potential-free alarm contacts that indicate tripping of the overheating protection with manual reset.

Control by means of built-in regulator for 0...10V control signal.

Control with accessories

There are several ways of controlling a VFL/VFLPG/VTL/VRA –MTXL heater. Three examples are presented here. For a complete wiring diagram, see the fitting instructions at our homepage www.veab.com (select Products/Duct heaters-Electric).

Master systems



0...10V



Ventilation unit that has built-in control with 0...10V output for reheater coil



0...10V



0...10V regulator control



0...10V



VFL, VFLPG, VTL and VRA

Rectangular electric duct heaters for external control equipment

The duct heaters are supplemented with external control equipment. It is important for this equipment to be matched to the heater and the power to be controlled. The table to the right provides guidance for suitable control equipment.

- M

Should preferably be controlled by a type PULSER or TTC regulator.

Selecting the output

The total output of a duct heater for external control equipment can be selected freely from 0.5 kW upwards. The output can be divided into a free number of output groups, with at least 0.3 kW and a maximum of 43 kW per output group (63A).

Connection of output steps

Standard

Main power supply 400V3~
0.3-3.5 kW: 400V2~
3.6-43.0 kW: 400V3~

Main power supply 230V3~
0.3-1.99 kW: 230V~
2.0-43.0 kW: 230V3~

To special order

0.3-3.6 kW: 230V~
0.3-6.0 kW: 400V2~
1.0-43.0 kW: 400V3~ or 230V3~



Project design/ordering

Descriptive text for - M

VEAB type VFLPG-1200-500-100kW-3x400V-M-A-IP43-NI-50C (see page 7) duct heater with the casing made of Aluzinc-coated sheet steel, AZ 185 that conforms to the requirements for corrosivity class C4. The heater elements are made of stainless steel to EN 1.4301.

Total output: 100 kW.

Output steps: 25 kW+25 kW+25 kW+25 kW.

Control by external regulator and sensor that must be ordered separately.

Connection example

Max. 6 kW, 400V2~

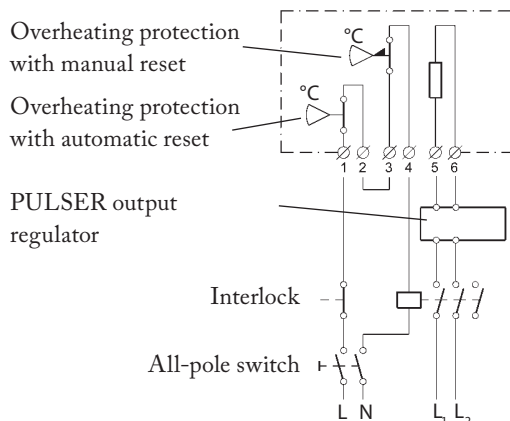

VFL / VFLPG / VTL / VRA

Connection example

Max. 81 kW, 400V3~

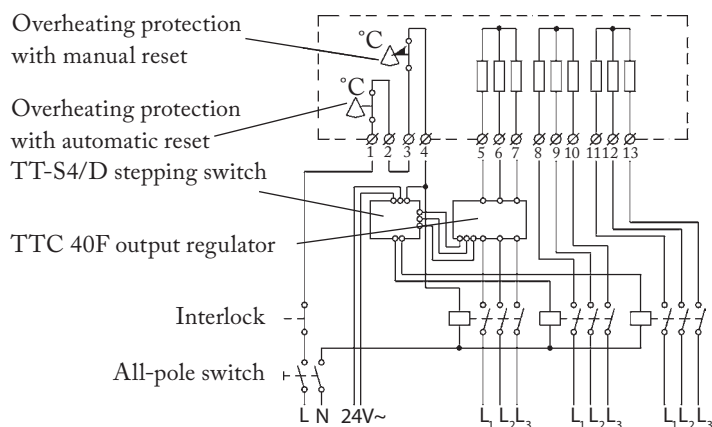

Selecting the regulator

Total output	Output steps	Regulators
0.5 - 6.0 kW	1 step, 400V2~	PULSER
6.1 - 17.0 kW	1 step, 400V3~	TTC 25 or TTC 2000
17.1 - 27.0 kW	1 step, 400V3~	TTC 40 F
17.1 - 34.0 kW	2 steps (1/2 + 1/2), 400V3~	TTC 2000 + TT-S1
28.0 - 54.0 kW	2 steps (1/2 + 1/2), 400V3~	TTC 40 F + TT-S4/D
55.0 - 81.0 kW	3 steps (1/3 + 1/3 + 1/3), 400V3~	TTC 40 F + TT-S4/D
82.0 - 108.0 kW	4 steps (1/4 + 1/4 + 1/4 + 1/4), 400V3~	TTC 40 F + TT-S4/D
109.0 - 135.0 kW	5 steps (1/5+1/5+1/5+1/5+1/5), 400V3~	TTC 40 F + TT-S4/D
136.0 - 215.0 kW	Output ratio (1 + 1 + 2 + 4, 400V3~)	TTC 40 F + TT-S4/D

Regulators



PULSER



PULSER D



TTC 2000



TTC 40F



Step controller
TT-S4/D

PULSER series

A series of electric heater regulators that control the output by time proportional control (intermittent ON/OFF control), which provides very accurate temperature control.

Degree of protection IP30 (PULSER D IP20)

Max. load 230V~, 3200 W and 400V2~, 6400 W (PULSER DSP 230V~ 2300 W och 400V2~ 4000 W).

PULSER

The PULSER operates with one sensor, i.e. the built-in room sensor or an external sensor, e.g. a duct sensor. Automatic switching between 230V~ and 400V2~.

PULSER D

Same characteristics as the PULSER, but for DIN rail mounting.

PULSER M

With an additional input for minimum or maximum sensor in the supply air duct*. PULSER M then controls the room temperature, at the same time maintaining a minimum supply air temperature. Automatic switching between 230V~ and 400V2~.

*Use duct sensor/minimum sensor TG-K330.

PULSER ADD

PULSER ADD has no sensor of its own but is under slave control from another PULSER and operates in parallel with it. This means that two duct heaters can be controlled by the same sensor. Automatic resetting between 230V~ and 400V2~.

PULSER 220 X010 and PULSER 380 X010

These regulators are controlled by an external 0...10V control signal. Supply voltage 230V~ and 400V2~ respectively.

TTC series

A series of electric heater regulators that control the output by time proportional control (intermittent ON/OFF control), which provides very accurate temperature control. The setpoint adjustment is set either on the TTC or on an external setpoint adjuster. The TTC series has terminals for external main sensor and min./max. sensor. Use the TG-K360 as min./max. sensor. As an alternative, the TTC series can be controlled by an external 0...10V control signal.

TTC 2000

For wall mounting.

Maximum installed power: 17 kW, 400V3~

Automatic switching: 210V - 415V3~

Degree of protection: IP30

TT-S1 circuit board

Fitted in the TTC 2000 for controlling one basic step of up to 17 kW. At least 50% of the total output must be controlled via the TTC 2000 and a maximum of 50% via the TT-S1.

The TTC 2000 and the TT-S1 can jointly control up to 17 kW + 17 kW = 34 kW.

TTC 25, TTC 40F and TTC 63F

For mounting on a DIN rail in an electrical cubicle.

Automatic switching: 210...415V3~

Degree of protection: IP20

Maximum power at the terminals:

TTC 25: 25 A, 400V, 17 kW

TTC 40F: 40 A, 400V, 27 kW

TTC 63F: 63 A, 400V, 43 kW

TT-S4/D step controller

Used together with the TTC 25, TTC 40F or TTC 63F for controlling the parts of the total output that exceeds their capacities.

Has four relay outputs that operate in sequence or by binary signals.

Outputs: 4x2 A, 240V~ normally open

Power supply: 24V~

Accessories

	Product	Range	Degree of protection
	Duct sensor TG-K330 for 220-400V*	0-30°C	IP20
	Duct sensor TG-K930 for 415-500V*		
	Duct sensor TG-K360 min/max sensor for the TTC series for 220-400V*	0-60°C	IP20
	Duct sensor TG-K960 min/max sensor for the TTC series for 415-500V*		
	Room sensor TG-R430 with set point adjustment for 220-400V*	0-30°C	IP30
	Room sensor TG-R930 with set point adjustment for 415-500V*		
	Room sensor TG-R530 for 220-500V*	0-30°C	IP30
	Room sensor TG-R630 for 220-500V*	0-30°C	IP54
	Pressure switch DTV200 incl connection kit	20 - 300 Pa Max 5 A, 230V~	IP54
	Pressure switch AFS-222	10 - 3000 Pa Max 15 A, 230V~	IP20
	Connection kit ANS	For AFS-222	

*Refers to the duct heaters supply voltage.



VEAB Heat Tech AB
Phone: +46(0)451-485 00 • Fax: +46(0)451-410 80
www.veab.com • veab@veab.com
Sweden